

DEGER S100-DR



SINGLE-AXIS TRACKING SYSTEM

Single-axis, active tracking systems from DEGER enable the optimal utilization of all the irradiation energy, suitable for all widely-sold solar modules. With the patented sensor-based MLD technology you can achieve yield increases of approx. 30% for all photovoltaic applications. An easy plug-and-play installation is

realized by means of the stable supporting construction. The decentralized control enables maximum independence. DEGER systems are "Designed in Germany"- and stand for quality and durability.

Rating chart using a sunny summer day as an example

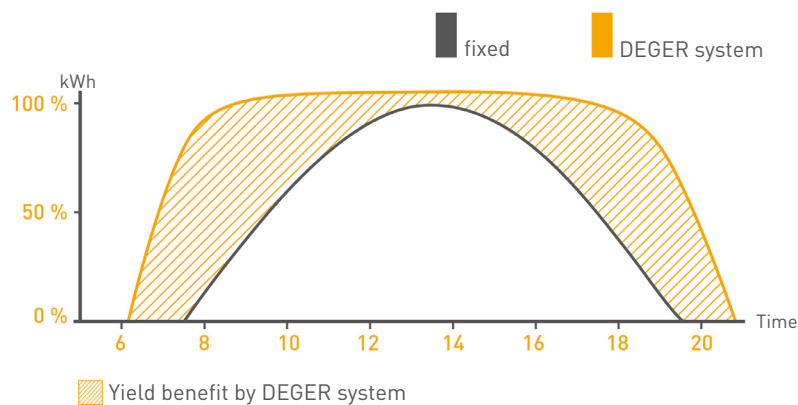

Advantages

- Yield increase with MLD-Technology
- Yield increase with snow sensor
- Fast and simple installation and easy handling
- Robust durable technology
- Automatic reset in initial position at night
- Up to 100 trackers to be managed by one Central Tracking Control (CTC)
- Wind guard with anemometer, in storm conditions DEGER system is placed automatically in security position
- Monitoring and DEGER Shadow Management System

Technology

- Efficiency with intelligent tracking
- Maximum Light Detection control concept
- Low power consumption

Technical Specification

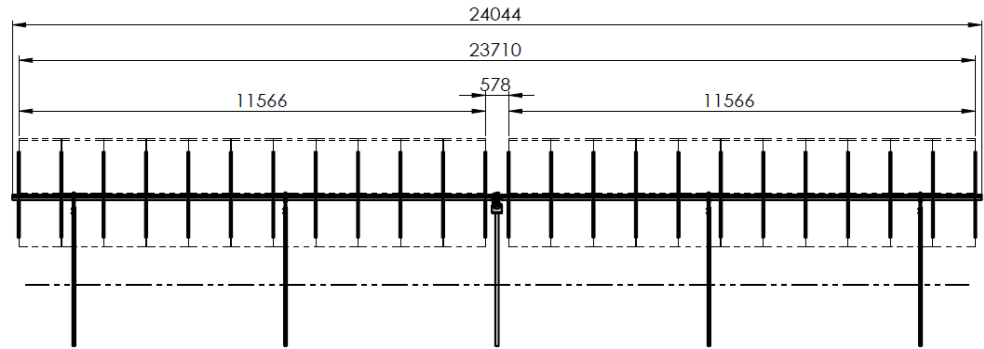

DEGER S100-DR
with driven pile foundation ⁽¹⁾

BASIC DATA

Nominal output (depending on module)	11,000 - 12,320 Wp DC
Tracking type	1-axis
Module surface approx.	78,6 m ²
Max. module surface (W x H)	2 x 11,57 m x 3,4 m
60-cell Standard Module (max.)	44
Elevation angle	0°
Approvals	CE, UL

STRUCTURE

Materials	hot-dip galvanized steel, aluminum, synthetics
Galvanization	EN ISO 1461 or comparable
Bond-Type	bolted connection, no welding on site
Certified statics	yes
Weight (without mast/aluminum)	project specific

DRIVE

Principle	maintenance free screw drive
East-West angle (with snow)	+50° / - 70°
East-West angle (without snow)	+/- 55°
Spin speed	18°/min.
Sound level (without load)	at a distance of 10 meters: 20-40 dB(A)
Protection class	IP 65

ELECTRONICS & CONTROL

Operating voltage	100 – 240 V AC / 50 – 60 Hz
Rated input current	2,3 A
Control	MLD-Technology
Protection class	IP 54

Technical Specification

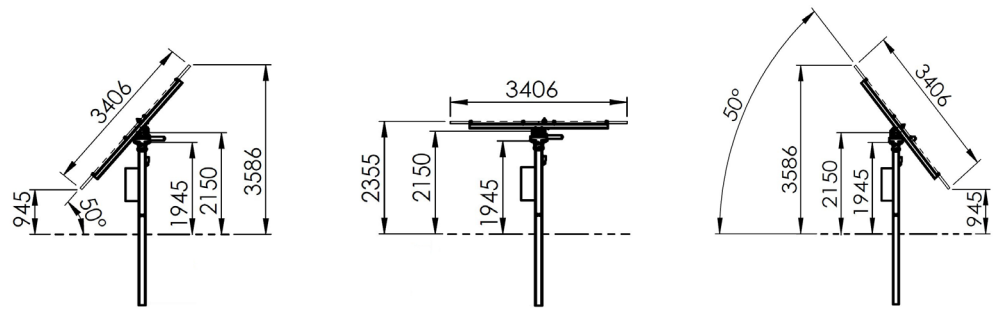

DEGER S100-DR
with driven pile foundation ⁽¹⁾

POWER CONSUMPTION (APPROX)

Control mode	1 W
With running actuator	50 W – 240 W
Internal consumption per year	5 kWh

POWER OUTPUT

Output voltage	24 V DC
Output current (max.)	10 A

CLIMATIC CONDITIONS

Installation over sea level	max. 2000 m
Permissible ambient temperature	-20°C – +50°C
Humidity range	5% – 95%
Permitted wind speed	110 km/h ⁽²⁾

GROUND CONDITIONS

Max. ground inclination East-West	10°
Max. ground inclination North-South	10° ⁽³⁾
Subsoil requirements	soil survey necessary

PILE DRIVING FLEXIBILITY

Ramming accuracy related to axis	max. +/- 25 mm
Axis twist angle	max. +/- 5°
Ramming accuracy in height	max. +/- 10 mm

(1) The depth of the driven pile foundation must be statically calculated. Pictured dimensions can change depending on the module size and/or number of modules per tracking system.

(2) With full occupancy – Laid out with Planning Tool

(3) Tracker axis installed parallel to the ground

SCOPE OF DELIVERY

Complete single-axis tracking systems, solar module carrier system made of steel - matching the module type used, patented MLD control (Maximum Light Detection) with MLD sensor and assembly instructions.

OPTIONAL SERVICES

Assembly support, trainings and on-site service.

WE ARE AT YOUR SERVICE.
WORLDWIDE.

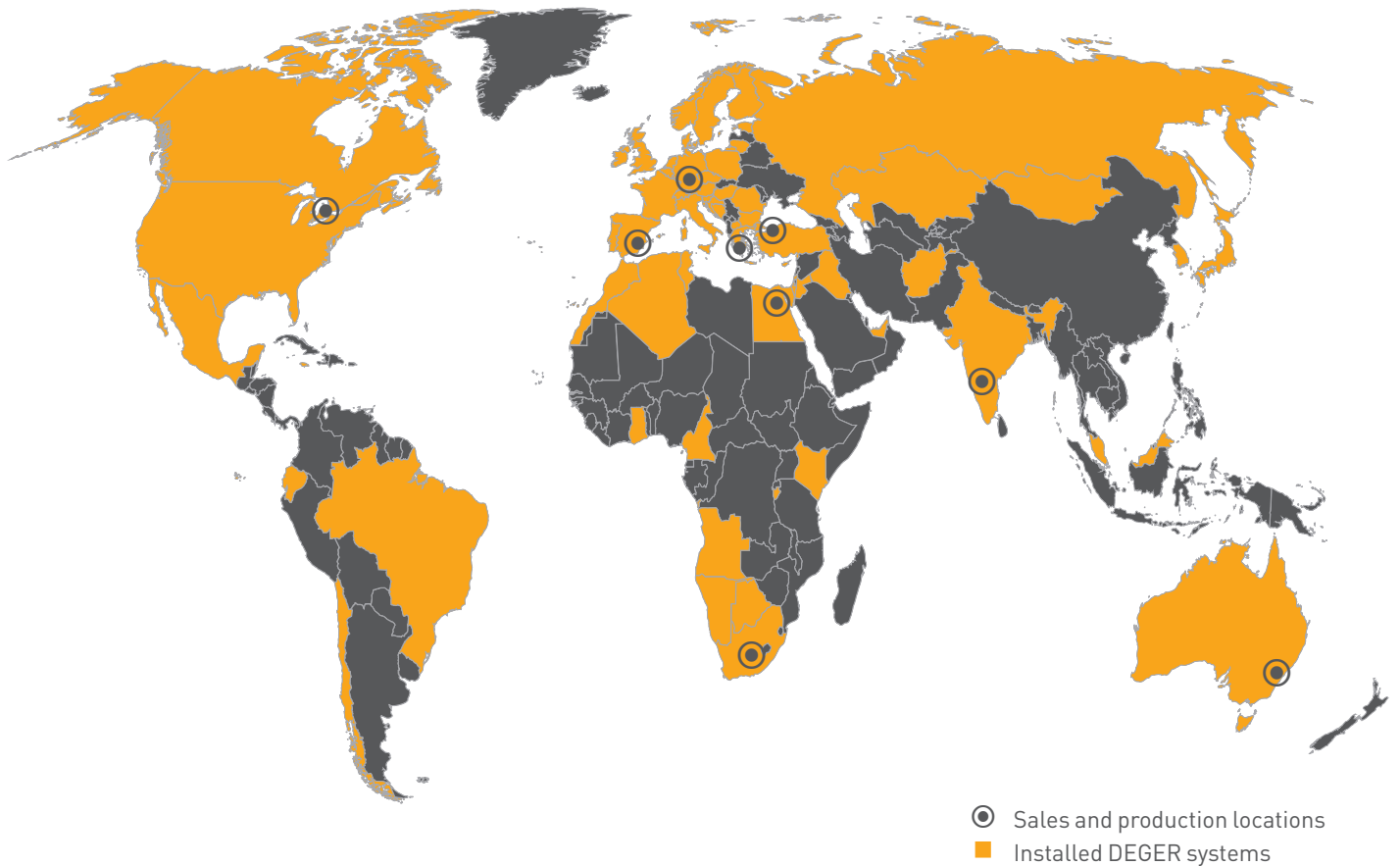

DEGERenergie GmbH & Co. KG
Industriestraße 70
72160 Horb am Neckar
Germany

Phone +49 74 51 53 914-0
Fax +49 74 51 53 914-10
info@DEGERenergie.com
www.DEGER.biz